

## TELEMETRY SYSTEMS

### SENSOR SOLUTIONS

*for strain gauge and  
temperature measurements*

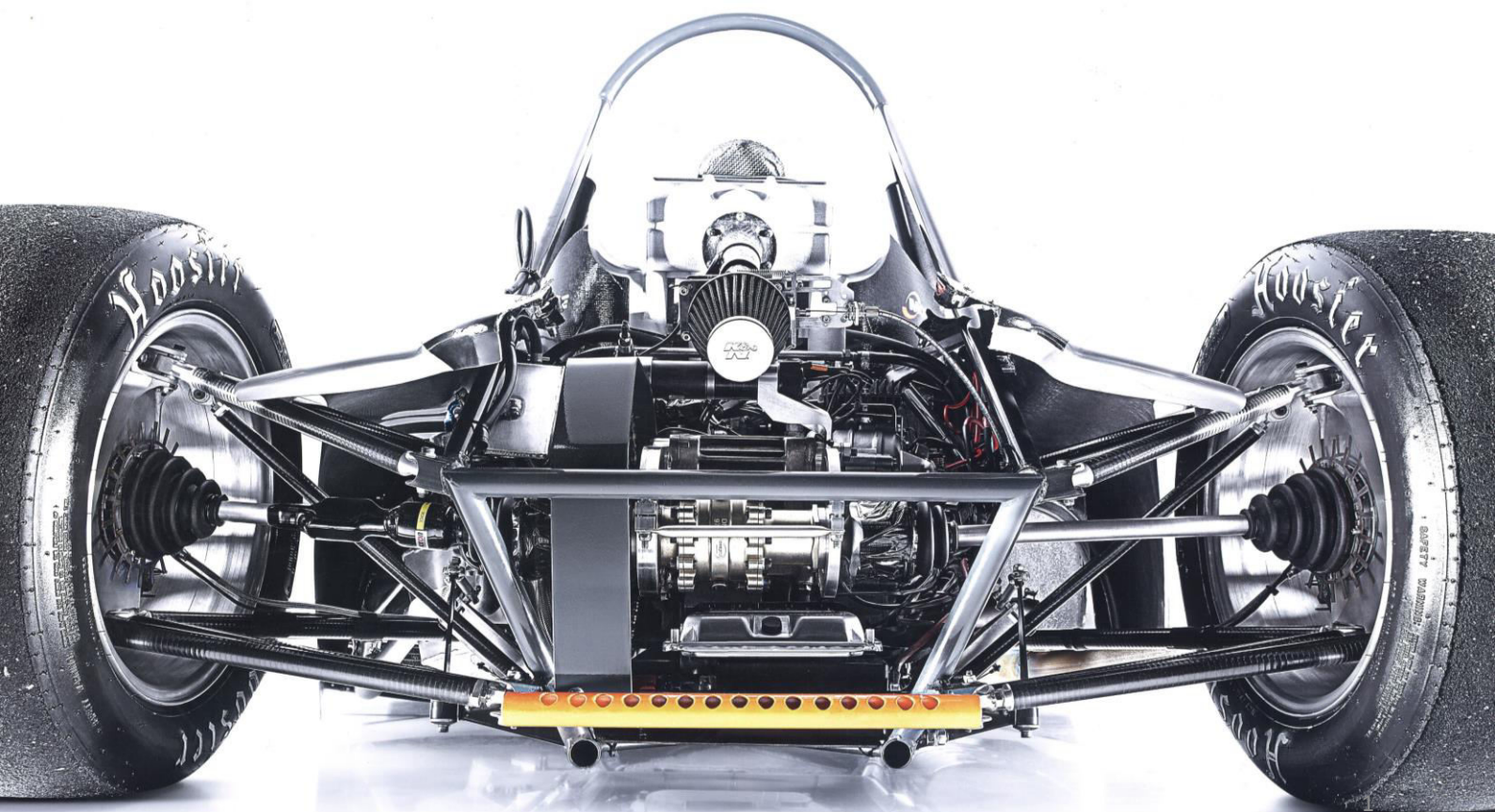

valuable insights  
drivetrain and transmission measurements



### Telemetry systems for tough everyday testing

The measurement of physical values on rotating vehicle and machine components is an important feature in the development of modern drive systems. AXON telemetry systems have been specially developed for this kind of rotating applications. Inductive power supply together with RF data transmission ensures absolutely **contact-free** and therefore **wear-free** operation. Various functionality parameters are constantly monitored and adjusted during operation. Numerous automatic background-processes ensure stable and reliable operation of the measuring

system and make it particularly easy and reliable to use. The telemetry systems deliver precise measurement results even under especially harsh environmental conditions (**temperature, dirt, oil, etc.**) in the demanding environment of **engines, test benches or in vehicles**. Whether the measurement is to be carried out on an automotive drive shaft, in the gearbox of a wind turbine or on a test bench - AXON telemetry systems offer high-quality solutions for reliable measurement results and represent real added value in the development of modern drives.

### Telemetric drivetrain measurements

- high-quality telemetry systems guarantee **reliable measurement results**
- precise acquisition of **torque, force and temperature**
- absolutely contactless and **wear-free**

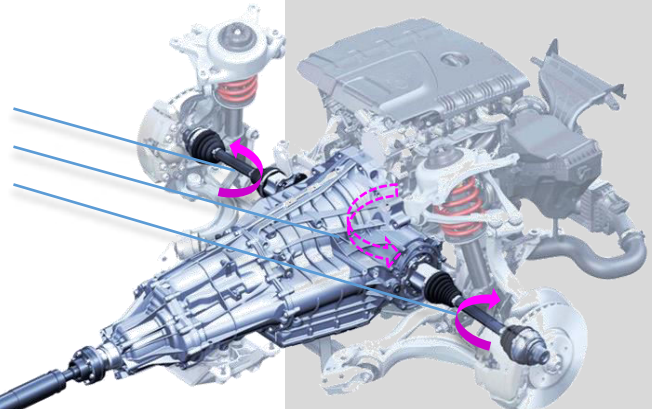
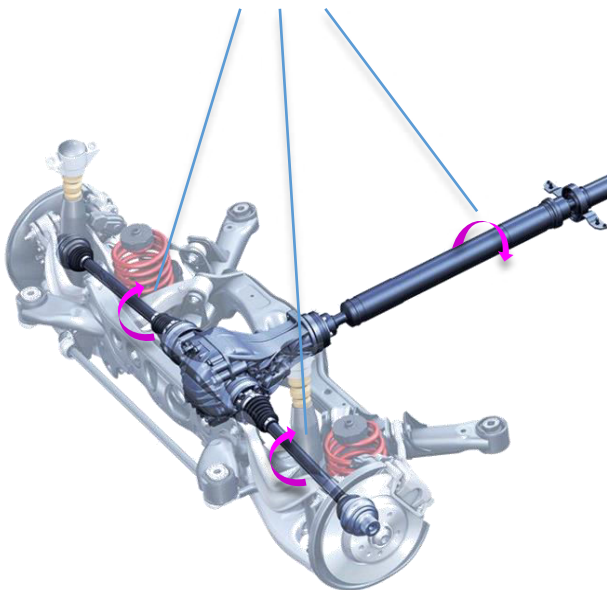

reliable **inductive power transmission** through intelligent control

components within the measuring chain **exchangeable**

extremely **high operating temperatures** even in continuous operation

easy installation - extremely **reliable**

absolutely **wear-free**

**CE certified**

one turn ahead...  
high quality telemetry systems

**State-of-the-art technology robustly packaged**

- inductive power supply over long distances - no batteries required
- high-precision signal acquisition and digitization directly on the shaft
- flexibility for a wide variety of installation situations
- precise analog and digital data output
- stable signal transmission even in oil and water

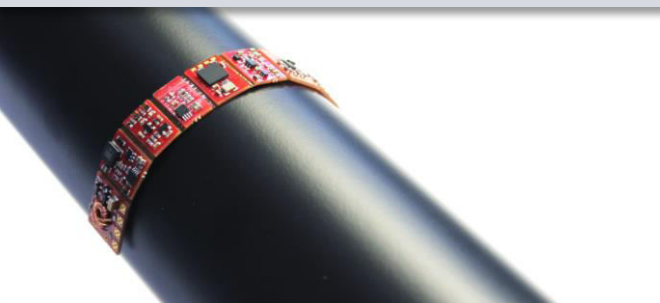
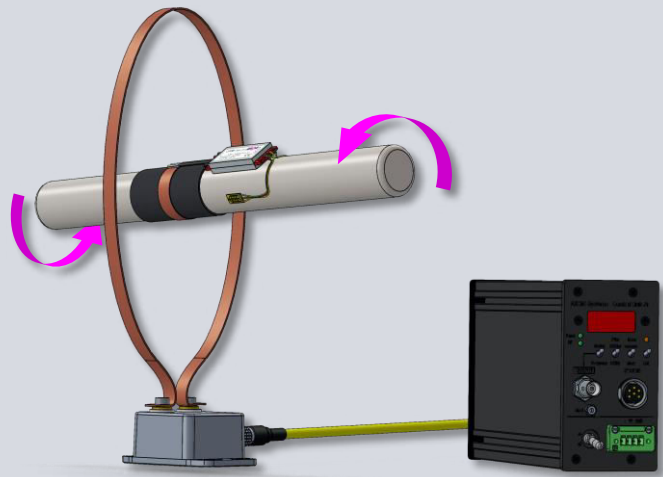

- **Rotor Unit** - precision sensor signal amplifier - miniaturized in the smallest space
- operating temperature up to 140°C in continuous operation
- different designs for wide range of applications



- **Stator Unit** with flexible ring antenna. Any size - any shape
- powerful inductive supply - long-term stable, CE compliant
- reliable transmission even with long suspension travel and longitudinal displacement of the shaft



- **Control Unit** - intelligent system centre
- analog and digital signal outputs
- simple operation - operating errors on the device virtually impossible

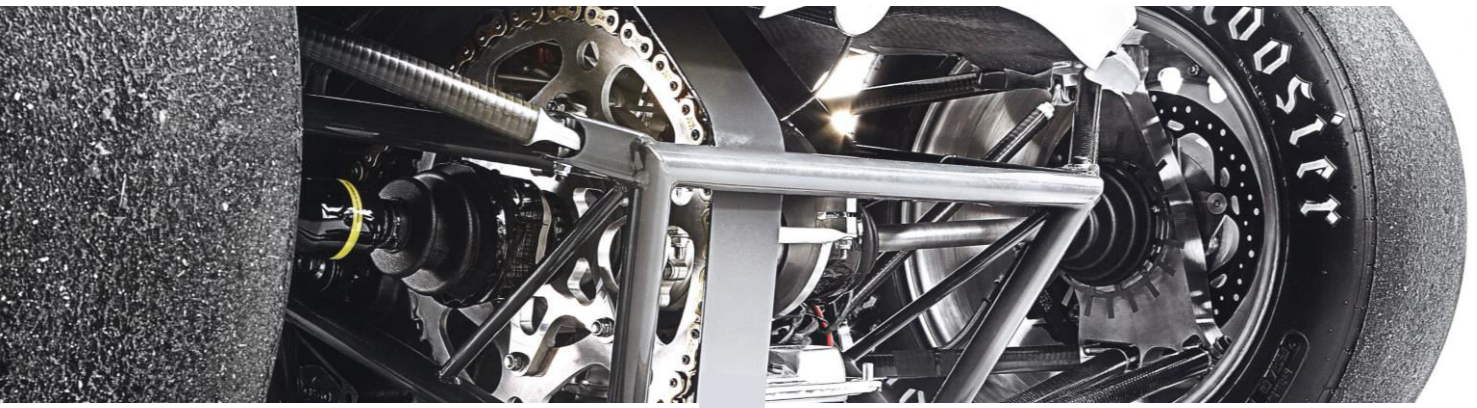

**Wireless torque- and temperature measurements on:**

- drive shafts
- prop shafts and cardan shafts
- gearbox input
- crankshaft
- gearbox output
- clutches (e.g. fin temperature)
- flexplates
- gears
- brakes
- flywheel brake dynamometers
- electric engines
- and many more

**The direct way to your more efficient testing:**

- very short delivery times
- uncomplicated commissioning
- high reliability
- durable technology
- free support - directly reachable by phone

***IPT: optimally supplied***

Intelligent Power Transmission (IPT) enables an uninterrupted inductive power supply for the rotating components, even with large deflections of the measuring shaft in all directions. A constant power supply is guaranteed with an air gap of several centimeters. Measurements can be performed without even with large suspension travel or axial displacements.

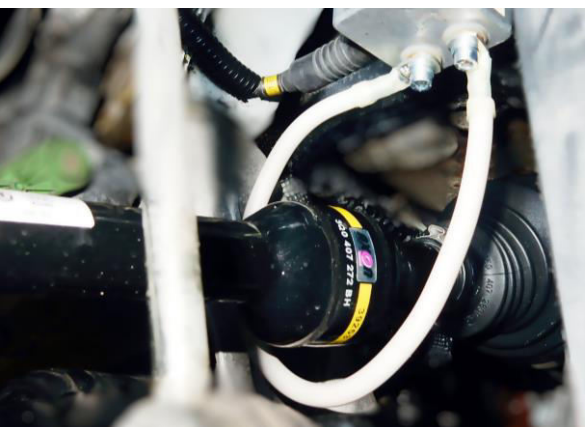
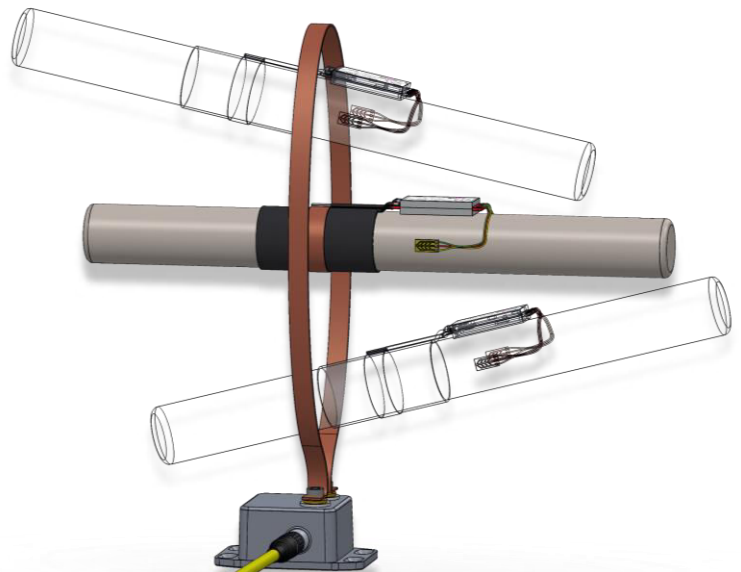

more  
performance

less power  
consumption

**Inductive power supply 4.0**

*Active control of the inductive supply to an optimum*

Continuous monitoring of the inductive supply increases performance where necessary and reduces it where possible. In a large number of applications, the power consumption of the telemetry system is reduced by 60%.

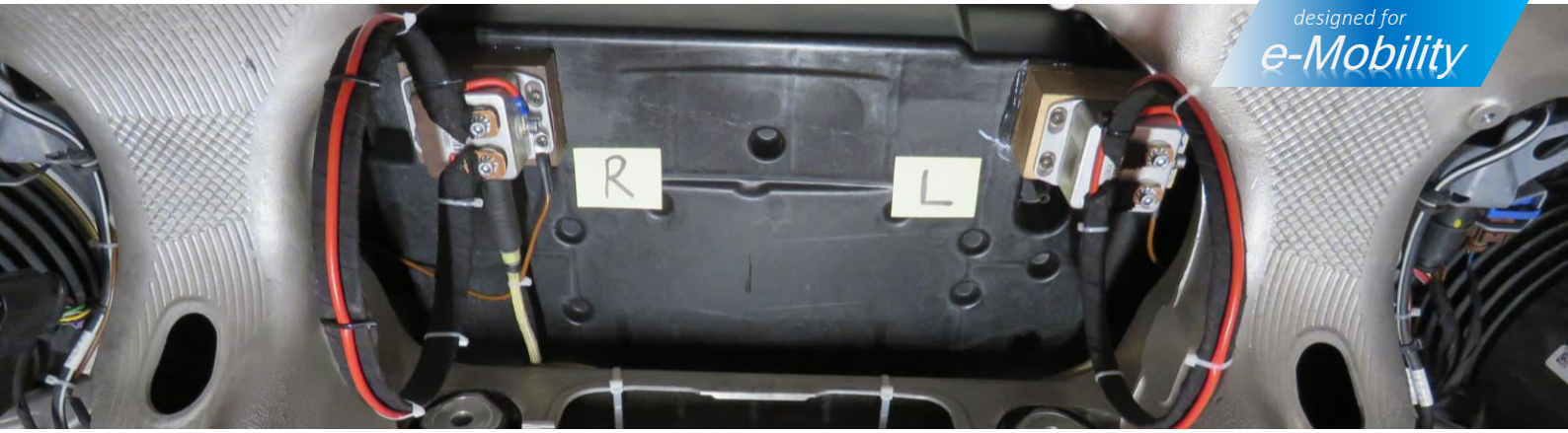

### Option **e**

- Ready for the future - special applications for **e-mobility**
- Active suppression of **strong EMC** interference fields directly at the receiving antenna
- Ideal for use in **electric vehicles** or on test benches with **frequency converters**
- Reliable measurement data transmission even directly **inside electric motors** (e.g. temperature measurement of the magnetic packs)
- Fully compatible with existing J-series telemetry systems
- Robust, oil and waterproof

### Innovation

#### Stators for areas of application exposed to high levels of EMC

New, innovative stators face the challenge of transferring sensitive measurement data safely and without interruption even under the influence of strong electromagnetic interference fields.

For the first time, AXON Systems offers specialized solutions for the operation of telemetry systems in **electric vehicles**. Especially during the early stages of development of new e-drives and vehicles, electric motors can generate strong electromagnetic interference that can interrupt the contactless data transmission of telemetry systems. If the measured value is recorded directly on the drive train (e.g. measurement of the drive torque), the influences can be extreme.

Stators with option E are equipped with an effective interference suppression of the received signals and suppress interference directly at the receiving antenna. The Stator Units are fully compatible with existing AXON telemetry systems. Different antenna solutions allow the flexible use of the ring stators, adapted to almost every situation.

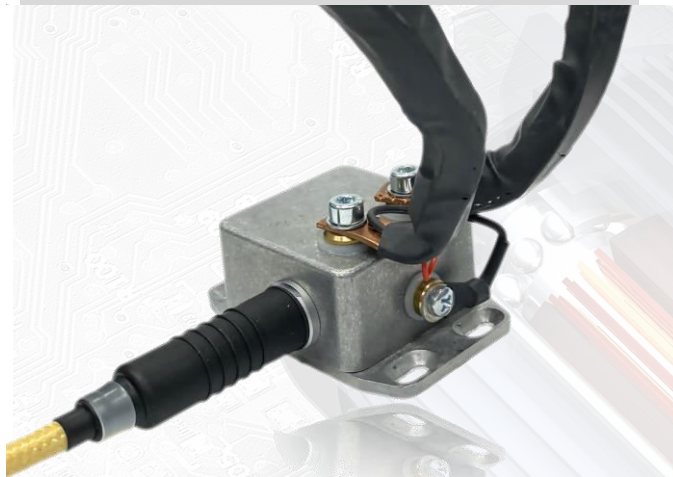

- Torque measurements in **eDrive** applications
- Test bench measurements with **electric drive**
- Temperature measurements in **electric motors**
- Use in **flywheel brake dynamometers**

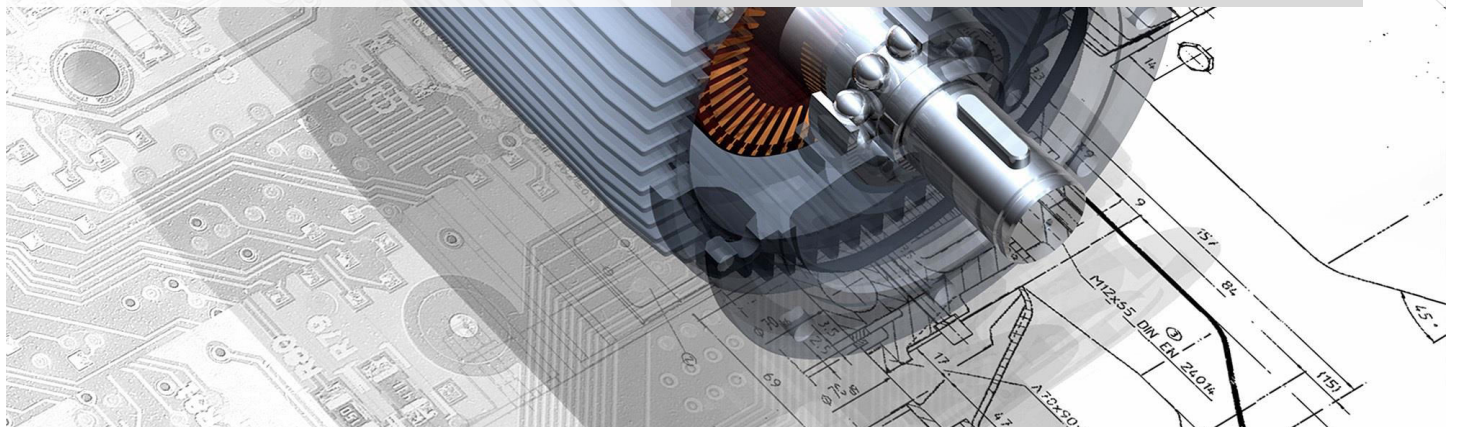

## Product presentation

### AXON J1DB

easy to use - everything at a glance – CAN-Bus output

Today torque measurements are standard applications for telemetry systems. The focus is both on simple handling and particular on the greatest possible reliability and failsafe performance. It is particularly advantageous to be able to check operational parameters at a glance in addition to the actual measurement data.

The system J1DB offers the possibility of checking the inductively transmitted supply voltage of the Rotor Unit during operation. In addition, based on this information, the system can actively control the inductive power transmission and continuously regulate it to an optimal value. Furthermore, the system's RSSI output allows the reception strength of the measurement data to be assessed. Finally, the system's shunt-calibration function enables quick and reliable calibration checking of the measuring chain and, where appropriate, of the peripheral data acquisition. The system has a **CAN bus interface** which digitally transmits not only the measurement data as voltage [V] or torque [Nm] signal but also numerous other useful information via an independent status ID (rotor supply voltage, rotor serial number, device name, calibration factor, sampling rate etc.). The configuration and setup is easy by using the supplied software and can be exported via .dbc file. Like all J-series telemetry systems, the J1DB can be used permanently at operating temperatures of up to 140°C. Different Rotor-, Stator- and Control Units are available, which can be combined with one another as required.

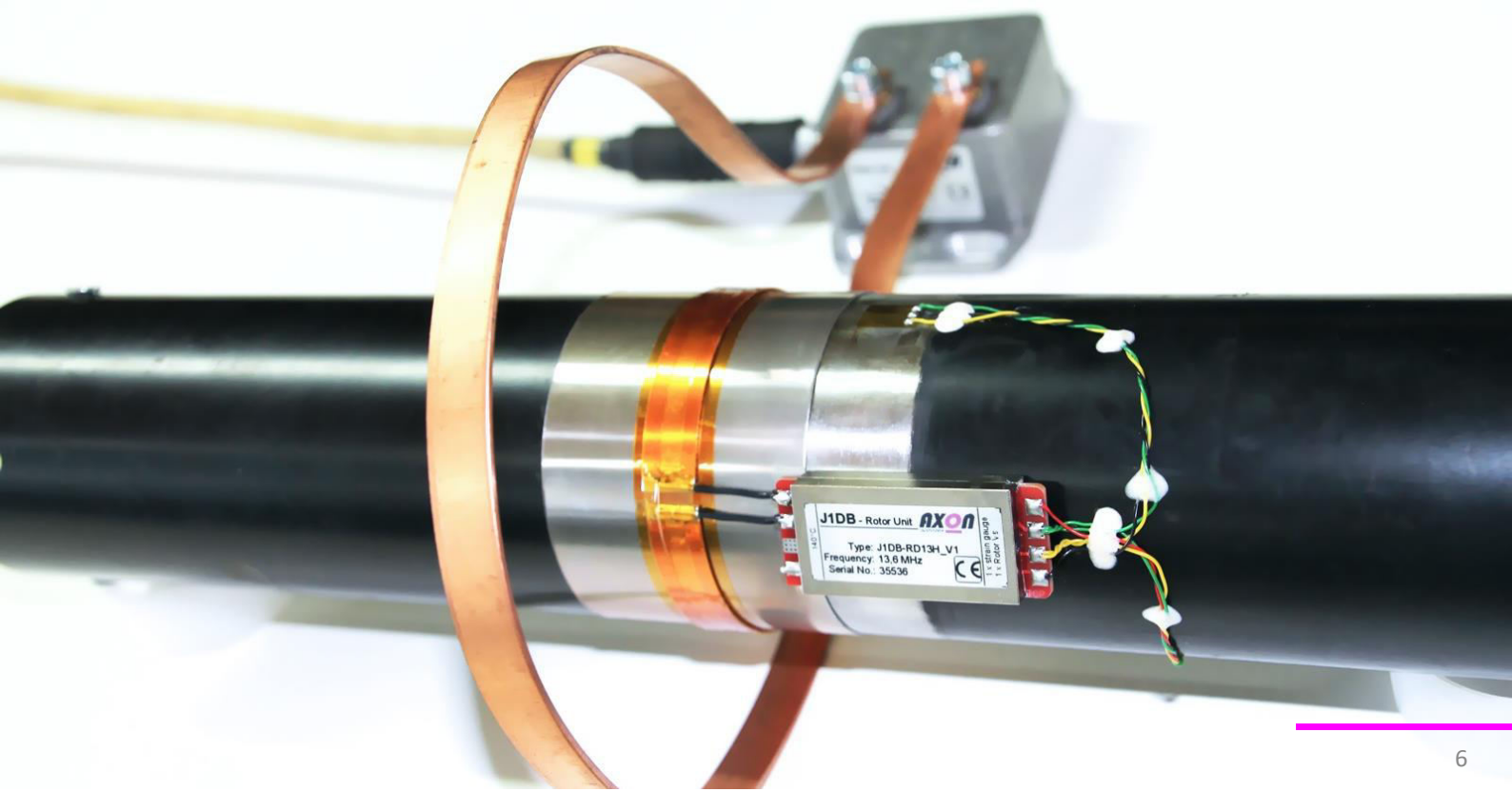

## Powerful tiny... cylindrical Rotor Unit

### News

#### Miniature Rotor Unit for strain gauge measurements

The new J1DB Rotor Unit for strain gauge measurements can be installed space-saving due to its cylindrical design with a diameter of only 21mm in central bores of shafts, flanges or gears.

The electronics are embedded in a carbon fiber housing, sealed oil and water-tight and thus offer all functions of the successful J1DB series, of course including inductive power supply in the **smallest space**.

All connections are easily accessible via high-quality solder

pads. In addition to the measurement data, the digitally transmitted data stream of the miniature transmitter contains information such as the currently available supply voltage and its own serial number for identification. Within the J1DB series, the rotor unit is of course interchangeable and can also be used with existing systems.



### Temperature measurement

#### Compact telemetry installation for the transmission of four thermocouple signals

In addition to the classic Rotor Unit in an aluminium housing, the telemetry system J4T now also offers a sensor signal amplifier in a **flexible design**. Signals from four thermocouples can be transmitted even in particularly complex applications without requiring a lot of installation space.

The Rotor Unit can be **"wrapped" around the shaft** - axial and radial installation space are reduced to a minimum. The simple antenna structure can be installed next to or on top of the Rotor Unit, depending on the space available. This installation can be accommodated in an axial installation space of only 20mm - of course including inductive energy transfer, which makes a battery on the shaft unnecessary and ensures uninterrupted operation even for long term measurements.

Classic applications include temperature measurements in clutch plates, gears, joints, electric motors or bearings. Due to the low weight of the flexible Rotor Unit J4T-RF, it is also ideal for use on electric motors with very high speeds (e.g. temperature measurement of the rotor magnet packs).



telemetry – installation - calibration  
all from a single source



Custom sensors

10 days ...

... this is just how long our customers usually wait for a completely customised measuring shaft - fully assembled and calibrated.

Our own demands on our products and developments are continued in customer-specific installations. Uncompromisingly **high-quality materials** and complex work steps guarantee tailor-made sensors of the highest quality. Each individual application is planned in detail and adjusted to conditions such as installation space, temperature and other environmental influences.

**Own torque test benches** (10kNm and 5kNm) as well as a **tension/pressure test stand** (50kN) enable the measurement equipment to be provided from a single source.

Together with our customers, we analyze the installation space situation using CAD data or even directly on the vehicle or machine. We then plan the application with the corresponding models and drawings and thus implement a sensor that is individually **tailored to the task**. Specialized and precisely coordinated processes and the enormous vertical range of manufacture enable **fast reaction and delivery times**.

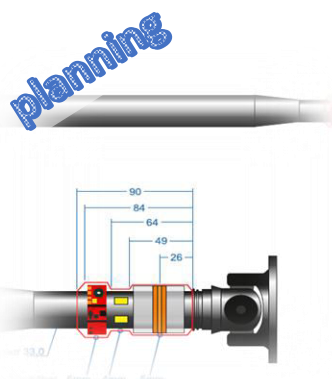
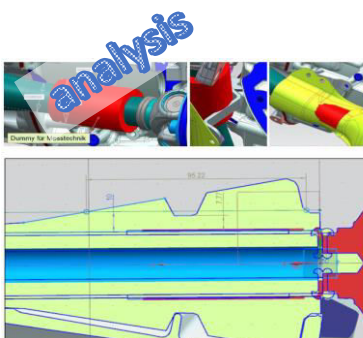





AXON APT

**A solid concept**

In order for high-quality measurement technology and sensors to provide reliable measurement results in any environment over a long period, high-quality measurement technology and an equally powerful protective cover are required. AXON APT (adaptive protection technology) sets new standards in this regard.

Many years of experience and the constant further development of the GRP (glass fibre reinforced plastic) protective cover consisting of several individual layers guarantee maximum durability, even when used in (salt) water, oil, at high temperatures and at high speeds. Mechanical decoupling and elastic intermediate layers make the structure just as flexible against extreme twisting as it is high-strength against stone chips or similar. At high speeds and G-forces, APT ensures that the measurement technology and sensors remain in place. Regardless of whether it is a rotating telemetry application or a wired measuring point - APT is the ideal protection for reliable long-term measurement results.

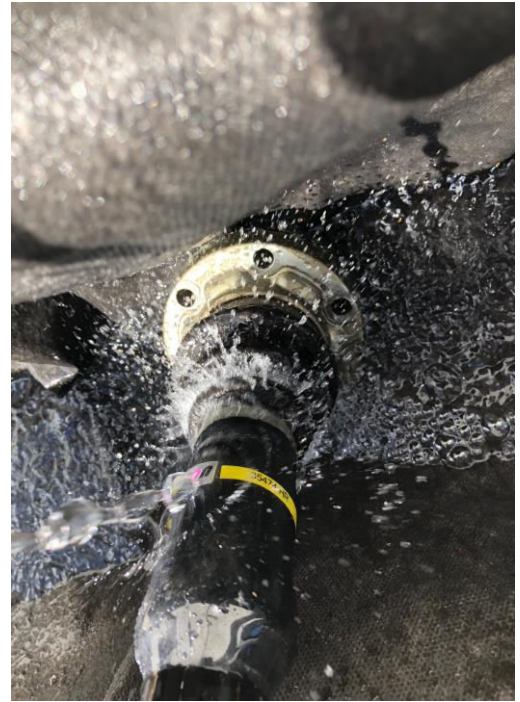

- turnkey **torque measuring** installations
- space saving rotating **temperature** measurements
- uninterrupted measurement data** during thousands of kilometers of testing
- reliable **load spectrum** measurements
- oil and salt water** resistant





Temperature measurement up to 12 channels

**Digital multi-channel telemetry systems for temperature measurements**

- high measuring ranges up to 1,250 °C
- Integrated linearization - easy postprocessing of the data

Besides strain gauge measurements, telemetries for transmitting thermocouple based signals are another important part of AXONs product portfolio. Systems for up to 12 measurement channels are available:

- **J1T:** 1 channel, measurements up to +715°C (thermocouple type K)
- **J2T:** 2 channels, measurements up to +910°C (thermocouple type K)
- **J4T:** 4 channels, measurements up to +715°C (thermocouple type K)
- **J4TH:** 4 channels measurements up to +1.250°C (div. thermocouple types)
- **J8T:** 8 channels, measurements up to +910°C (thermocouple type K)
- **J12TH:** 12 channels, measurements up to +1.250°C (div. thermocouple types)

**Features:**

- high measuring accuracy
- linearized signal output
- integrated cold junction compensation
- digital transmission

**Applications:**

- brake temperature measurement
- plate fin temperature measurement (clutches, differentials, etc.)
- joint- and lubricant temperature measurement
- temperature measurement in gearings
- temperature measurement in electric motors

Product presentation

**AXON J12TH - 12-channel telemetry for temperature measurements**

The J12TH telemetry system transmits the signals of twelve thermocouples on rotating components contactless and enables **temperature measurements of up to 1,250°C**. The miniature Rotor Unit allows precise measurements on rotating **shafts, brakes, clutches** or the like, even at high ambient temperatures.

Thanks to the latest inductive power transmission, the system works energy-efficiently and constantly provides additional information during operation, such as the available supply voltage on the rotating components as well as the reception quality. The thermocouples can be connected via miniature screw terminals as well as via solder pads.

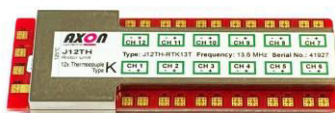

Brake temperature measurements up to 1,250°C

It's getting hot!

The temperature measurement on brake discs, especially the application on **flywheel brake dynamometers**, places very special demands on a telemetry system.

Long operating times require an absolutely maintenance-free system that delivers precise measurement results despite adverse environmental conditions.

High ambient temperatures, dust from abrasion and high EMC loads distributed by the electrical drive of the test bench often make reliable data transmission difficult. A stable data connection must be guaranteed, especially if the brake disc temperature is used to regulate the test sequences and incorrect data can lead to massive damage to the brake.

For these applications, AXON offers a wide range of suitable telemetry systems with up to 12 measuring channels for thermocouples and measuring ranges up to 1,250°C.

The latest telemetry systems J4TH and J12TH have not only the extended measuring ranges, but also the latest generation of contactless, inductive power transmission. This continuously regulates the supply voltage of the Rotor Unit to the optimal value during operation. The system's power consumption is thus continuously optimized. Both the rotor supply voltage and the quality of the received RF data (RSSI) can be monitored continuously, which ensures permanent reliable operation.



- transfers up to 12 thermocouple signals contact-free
- comfortable analog voltage output including linearization
- miniature Rotor Units as powerful and compact sensor signal amplifiers allow space-saving installations
- operating temperature up to 140°C in continuous operation
- high measuring accuracy



Rotor Units – compact and robust

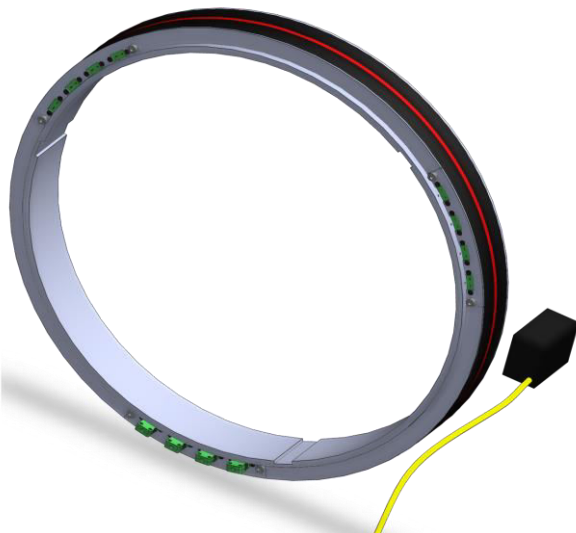

Plug & Play

Customized solutions for existing test benches allow easy integration of telemetry through retrofitting capability. Benefit from an individual and **ready-to-use construction** for your individual application. The thermocouples are connected, for example, via mini or micro thermocouple plugs.

High permissible operating temperatures of up to 140 °C allow operation close to the brake, which eliminates the need for complicated, long lines between the sensors and the telemetry installation.

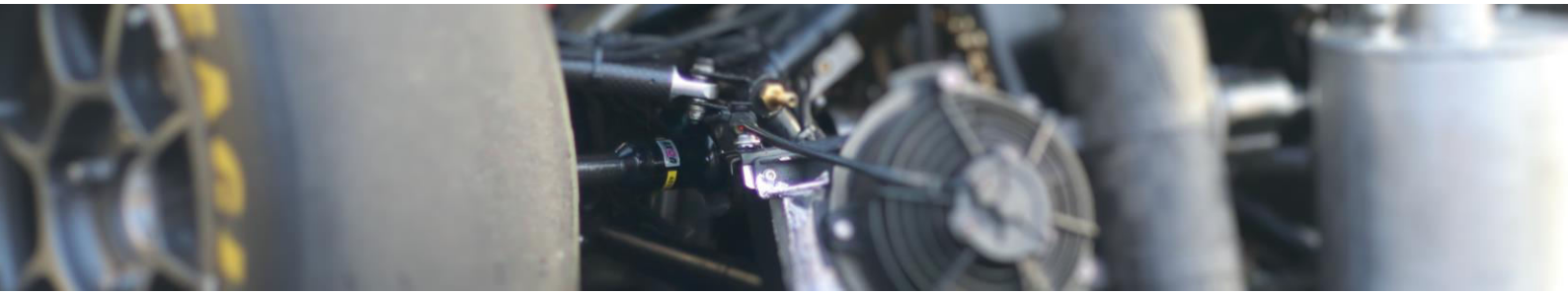

Application example

Temperature measurement in a rear axle transmission

The J4T telemetry system allows simultaneous transmission of four thermocouple signals on rotating shafts. The installation provides four thermocouple female connectors for easy accessibility. Sensor wiring is via a hollow shaft from the differential gearbox directly into the custom-built telemetry carrier, which is integrated into the powertrain along with a shortened propshaft. A highly efficient inductive power supply allows simple and uncomplicated installation both on the test bench and in the vehicle.

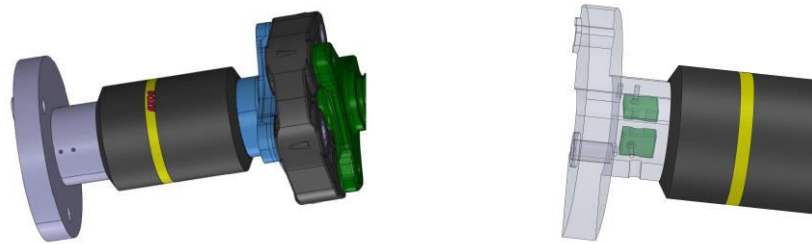

Connect thermocouples - done!

AXON telemetry systems for temperature measurements do **not require any configuration or adjustment steps**. The inductive power supply adjusts autonomously to all relevant conditions. Thus, the stator antenna of any size can be adapted to the rotating transducer directly on site.

Cold junction compensation and linearisation ensure the output signals of the telemetry can be processed directly. Each channel can be acquired as an analogue output voltage at the compact Control Unit.

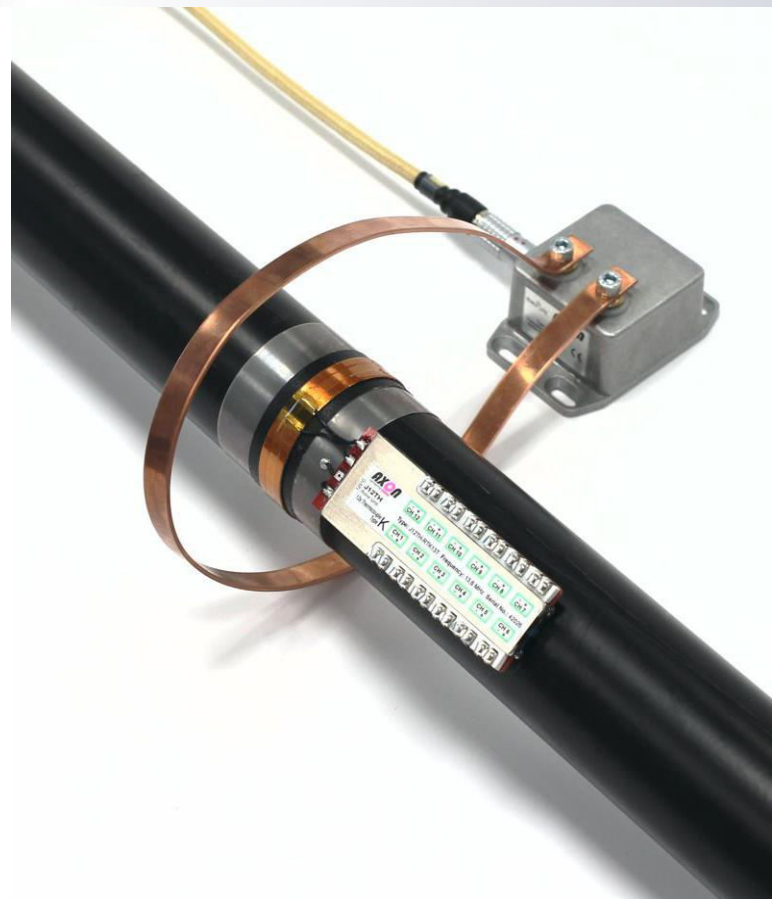

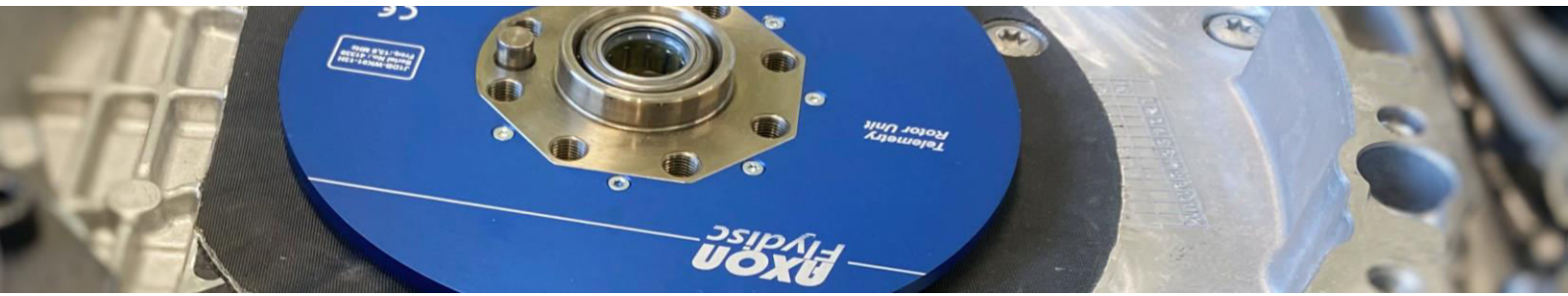

Torque measurement directly on the crankshaft

**AXON Flydisc - entire strain gauge telemetry on only 6mm**

Measuring and transmitting torque on a **crankshaft** is a particularly demanding task for a telemetry system. The measuring system must be able to withstand high operating temperatures and rotational speeds and at the same time take up as **little installation space** as possible.

Measuring just 6mm rotor width, the AXON Flydisc allows a complete telemetry system to be integrated in an **axial space of less than 10mm** - including stator antenna and highly reliable inductive power supply. For example, the **ultra-compact and lightweight** Flydisc fits between the engine and clutch and can measure torque directly at the crankshaft. Alongside measurement on the combustion engine, the system also allows torque measurements in gearboxes and other applications where installation space is critical.

Facing the Flydisc, a wafer-thin stator antenna can receive the data and at the same time provides the inductive power supply.

Optionally, an additional temperature channel is available together with the torque measuring channel.



**Did you know ... ?**

... AXON telemetry systems comply with the following EMC regulations?

R&TTE: EN 300 330-2 V1.5.1, EN 301 489-1 V1.9.2, EN 301 489-3 V1.6.1, EN 50364:2010, EN 55011:2009+A1:2010, EN 60950-1:2006 + A11:2009 + A12:2011 +, A1:2010 +A2:2013

Compliance with these guidelines ensures, among other things, that **no interference is generated** by the telemetry systems that is capable of influencing other electronic assemblies and systems.





## Force measurements on tie rods

### Robust strain gauge installations for long-term measurements

The measurement of forces on tie rods during vehicle testing provides valuable insights and, with the increasing complexity of steering systems, is becoming an important part of measurement tasks in driving tests. In addition to the greatest possible precision of the measurement, a robust sensor that is able to withstand the tough operating conditions on the open road or even off-road is extremely important.

The customer-specific installations AXON DMS-AF combine high-quality strain gauge applications with the extremely resistant, multi-layer protective cover APT for demanding measurement tasks. Therefore the sensor remains protected against oil, (salt-) water and stone chips even during long-term measurements - at temperatures of up to 160°C.

A direct strain gauge installation on the tie rods eliminates any mechanical modification in the vehicle and the test can be performed under absolute real conditions.



#### Strain gauge application / custom force transducers

- ideal for force measurement on tie rods
- adaptive Protection Technology for long-lasting precision even under the toughest conditions
- temperature stable up to 160°C
- In-house calibration up to 50kN
- oil and water resistant, suitable for long-term measurements even in salt water
- strain gauge installations using the high-quality and computer-aided hot bonding process



# TELEMETRY SENSOR SOLUTIONS

## FOCUSED ON ESSENTIALS

AXON Systems – your specialist partner in sensor solutions

from detailed planning and implementation to on-site support for commissioning and measurement

high end telemetry systems

uncompromisingly highest quality

delivery within just a few days

plug & play solutions from one source

fast, uncomplicated support

more than 20 years of experience



Contents and illustrations of this brochure were included written with the greatest possible care and to the best of our knowledge. Subject to errors and technical changes.

